

---

## 12 BOLT CORVETTE CONVERSION PARTS KIT

---

At this time we are not offering built third members! Sooo we've made a kit so you can do it yourself. Kit includes your choice of 12 Vette ratios 3.73, 4.11, or 4.56 ratios, a machined posi case (butt not polished) a set of 10-17 heat-treated spiders, an 18 solid clutch pack with shim kit, a Tom's cross shaft, 2-steel thrust washers and cross shaft bolt. One steel cap with bolts for both sides, a billet yoke in 1310, 1330, 3R or 1350 series. Along with a pinion nut, washer & crush sleeve. Also includes a complete third member bearing set including inner axle bearings & seals. Along with a set of available factory side shims an aftermarket set of pinion shims and a set of A.R.P. ring gear bolts!

**Please specify ratio & yoke size when ordering!**

**Part #12V-KIT**

**3.73 Ratio                      Price \$1835.00**

**4.11 or 4.56 Ratios        Price \$1885.00**



---

### ***Billet Case & Cover***

Late 2012

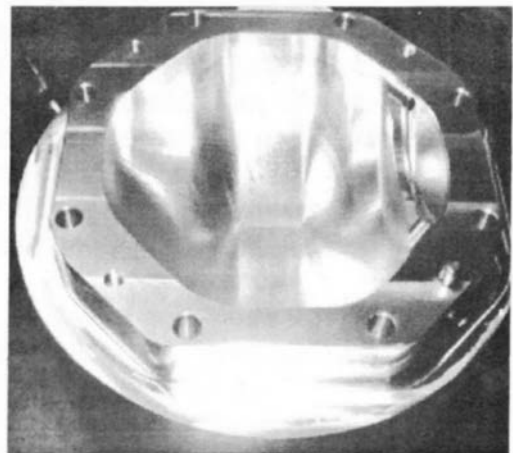
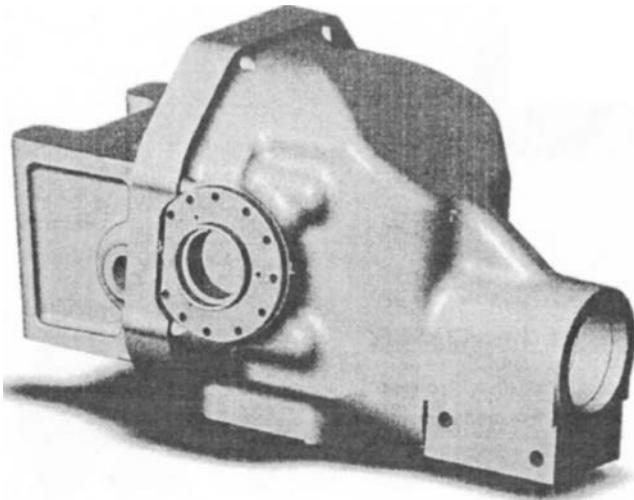

---

Prices Subject To Change  
Tom's Differentials

# 1963-1979 CORVETTE

## Ring and Pinion Sets

We offer a complete line of Corvette ring and pinion sets to suit your needs ratio wise. The last three part numbers are the gear ratios.



**Note!** '63-'64 Vette's used a 17 spline Pinion, So if replacing you will need a 30 spline yoke! See 12 Bolt Car Section for Yokes

### U.S. Gears

### Richmond Gears

**MADE IN AMERICA**



U.S. Gear Prices  
\$260.00 to \$270.00

- U10V-2.73-NLA
- U10V-3.08
- U10V-3.36
- U10V-3.55
- U10V-3.73
- U10V-4.11\*\*
- U10V-4.33\*\*
- U10V-4.56\*\*

- R10V-3.08
- R10V-3.23-NLA
- R10V-3.36
- R10V-3.55
- R10V-3.70
- R10V-3.90
- R10V-4.11\*

Richmond Gear Prices  
\$350.00



**NOTE!**

\* Requires use of 4-series carrier case or spacer.

Spacer Part #C10V-RGSpacer

\*\*Thick gear for 3-series carrier

### 12 Bolt Corvette Ring and Pinion Sets

12V-3.73	Price \$500.00
12V-4.11	Price \$550.00
12V-4.56	Price \$550.00

**NOTE!** 12 Bolt NOT a standard replacement

**MADE IN THE U.S. OF A.**



### Steel Cap

This steel cap and bigger bolts will make your ring and pinion live. Complete with bolts and instructions.

Part #C12-SC

Price \$80.00

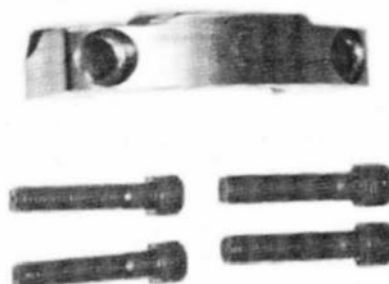

## 1963-1979 CORVETTE

### **Bearing Set**

This is a complete bearing, race and seal set for your Vette 3rd member. These are the same top quality pieces we use in all our famous Vette rears.

Includes Inner Axle Bearings and Seals.

Part #C10V-BS Price \$100.00

Less Inner Axle Bearings and Seals

Part #C10V-CBS Price \$80.00

#### **Additional Information**

Pinion Seal #8460

Front Pinion Bearing #88048 / Race #88010

Rear Pinion Bearing #802048 / Race #802011

Side Bearings #603049 / Races #603012

Axle Bearings #BH2212 / Seals #472258



### **Shim Kits**

These shim kits include a complete set of side shims and pinion shims. An assortment of shims is a must to do the job correctly.

Side Shims Only .064 thru .068 & .075 - .094

Part #C12-SS0 Price \$85.00

Aftermarket Shims

Super Side Shims

Part #SSS-12 Price \$25.00

Pinion shims

Part #AMPS-1100 Price \$8.00

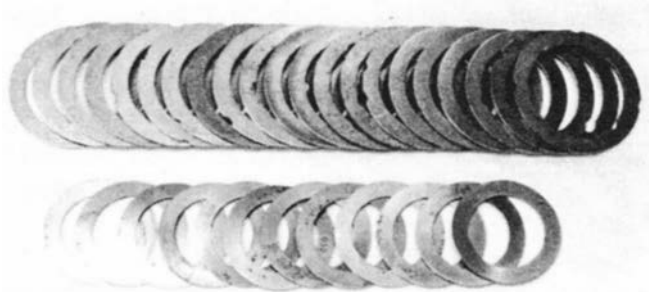

### **Crush Sleeves Pinion Nut & Gasket**

We offer the standard crush sleeve or an aftermarket crush sleeve with shims to obtain the desired preload "reusable" and of course pinion nut & gasket.

Aftermarket crush sleeve

Part #10V-CS Price \$6.00

Crush sleeve w/shims

Part #10V-CSS Price \$30.00

Pinion nut

Part #C12-PN Price \$5.50

Gasket

Part #10V-G Price \$4.00

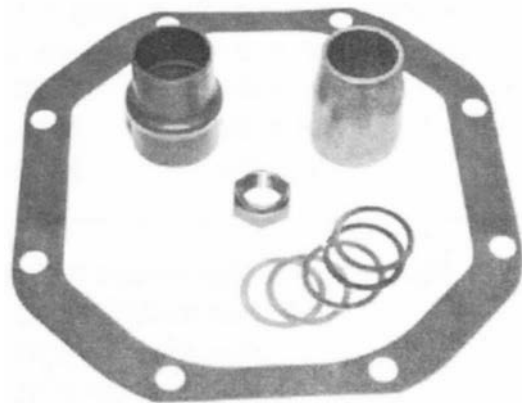

### **Installation Kit**

Installation Kit includes center bearing set, crush sleeve, pinion nut, gasket, Loctite, marking compound with brush, super side shims and some aftermarket pinion shims.

Part #C10V-IK Price \$120.00

CAUTION! 63-64 Vette 3rd Cases use 1 thin steel shim per side these case's must use factory side shim kit!

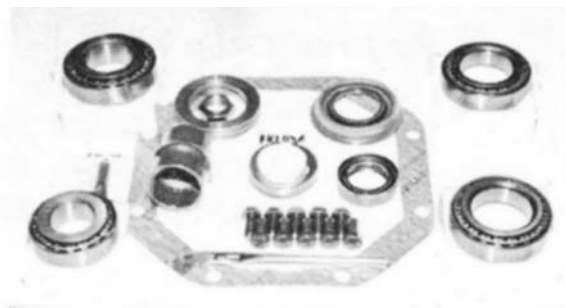

## 1963-1979 CORVETTE POSI CASES

**EATON**

We offer new posi case's in stock factory form, or with polished openings to help keep your posi case in one piece when used in performance apps. Accepts 2.73 through 3.70 ratio's along with Richmond 3.90 and **TOM'S** U.S. Thick Gears



Std case          Part #10V-PC3      Price \$375.00  
 Polished case   Part #10V-PC3P      Price \$485.00

We also offer posi cases that have been modified for use with 30 sp. axles polished or std.

**\*Note!** All units listed are 3-series  
 We now offer 4-series units in all the variations please specify if 4-series is needed!

30 sp. Standard    Part #10V-PC3-30      Price \$430.00  
 30 sp. Polished    Part #10V-PC3-30P      Price \$540.00

### **Posi's Units**

We offer the widest selection of posi units for 63-79 Corvettes. All are 3-series and are available for use with standard snap-ring inner axles, special K.A.17 spline inners for C-Clip axle retention, also for K.A. 30 spline inner axles for most severe use.

Part #10V-EP3          Price Too Low to Print          4 Series Also Available!

Stage 2 is a standard factory unit.

Stage 5 is a tuned unit where we eliminate the spring pack, replace the forged-formed spiders with cut 10-17s Add 18 solid clutch pack and tune for your application.

Stage 7 same as #5 with polished posi case to help eliminate case cracking with specially heat-treated spiders and Tom's Cross Shaft. B.O.E.

# B.O.E. = Best of Everything!

### **For Standard 17 sp. Snap ring Inners**

#2 STD. Unit    Part #10V-3P          To low to print  
 #5                    Part #10V-3P-5      \$794.00  
 #7                    Part #10V-3P-7      \$965.00

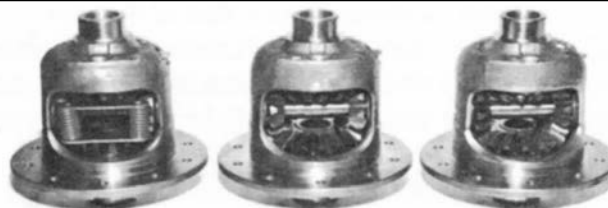

### **For 17 sp. C-clip Inners Axles**

4-Series also available!  
 Special Order

#5                    Part #10V-3P-5CC    \$800.00  
 #7                    Part #10V-3P-7CC    \$965.00



### **For 30 sp. C-clip Axles**

#5                    Part #10V-3P-530    \$860.00  
 #7                    Part #10V-3P-730    \$1020.00

### **Tom's C-Clips**

**NEW!** We offer a variety of double disc ground C-Clips for when you tune your posi and require a thinner C-Clip so you don't have to grind you axle tip.

Available in thicknesses of .105, .110, .115, .120, .126, .130, .135, .138 & .143  
 Special Ground C-Clips – Please Specify Thickness      Price \$6.00 Each  
 Standard C-Clip is .148-.150                                      Part #C12-CC      Price \$3.00 Each



### **Get Help!**

Visit Tom's Differentials Youtube Channel to watch "Posi Tune-Up" Tutorial Video, which includes a section on setting Axle End-Play. Other helpful Instructional Videos are also available for FREE!

# 1963-1979 CORVETTE

---

## **Posi Spider Gears and Cross Shafts**

We offer the largest selection of 10-17 spiders for 63-79 Corvettes. 17 spline standard replacements, 17 sp. for use with K.A. axles using c-clips and 30 spline for abusive applications. All sets are available for use with standard cross shaft size over bore cross shaft and in standard or specially heat-treated sets.

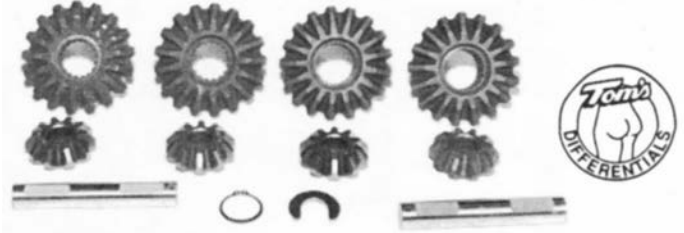

<b>New!</b> Forged Formed Spiders	Part #10V-1017-2	Price Special \$60.00
Std 17 sp. replacement Cut Gears	Part #10V-1017	Price \$165.00 set
17 sp. for c-clips Cut Gears	Part #10V-1017-CC	Price \$165.00 set
30 sp. for c-clips Cut Gears	Part #10V-1017-30	Price \$165.00 set
For special heat treated add H.T. to part # and add \$50.00 to price.		

**MADE IN USA**

### **Thrust Washers**

Part #10V-TW Price \$3.25 Each



---

### **Cross Shafts**

Stock Eaton Cross Shaft

Part #ECS-10V Price \$18.00

We offer Tom's Cross Shafts manufactured from 8620 steel, heat-treated to 57-58 hardness and precision ground creating the finest cross shafts offered.

Standard size cross shaft  
Part # TCS-10V Price \$30.00  
Cross shaft for large bore  
Part # TCS-10-12V Price \$30.00

**Note!** See posi cases for additional info

**For Posi Plates and Posi Shims see 12-Bolt Eaton Section**

---

### **H.D. Rear Cover**

We offer Muskegon Brakes heavy duty rear cover for two reasons. Its beefy and its easy on the wallet. For 2-1/4" spring w/ 9/16 bolts

Part #C10V-HDRC Price \$150.00

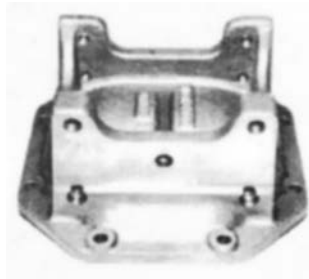

**MADE IN USA**





---

### **3rd Member Case and Caps**

G.M. discontinued this part 2 of 1992 so we can only offer good used cases at this time.

Price standard \$275.00

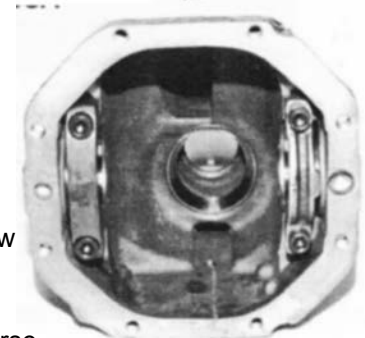
**MADE IN USA**



Sometime in 2012 New billet alum. cases Will be available Made in U.S.A. of course

# 1963-1979 CORVETTE

## Outer Drive Axles

Here's another fine axle from KA., Manufactured from 1541 material, induction heat-treated and precision ground with dual pattern of STD. 7/16" or 1/2" x 3" press in studs. What an axle and what a price. NOTE! Also fits 80-82 Corvette

Axle	Part #KAV-ODA	Price \$115.00 ea.
Drive Flange	Part #V-DF	Price \$63.50 ea.
Bolt on D.F.	Part #V-BDF	Price \$40.00 ea.
Tom's billet bolt on D.F.	Part #TV-BDFB	Price \$135.00 ea.
Cotter Pin	Part #V-CP	Price \$1.00 ea.
Nut	Part #V-NUT	Price \$3.00 ea.
Washer	Part #V-WA	Price \$6.00 ea.



MADE IN U.S.A.



## Outer Axle Bearings

A set of top of the line quality bearings, races and seals for your babe (Vette). Quality results require quality components.

Part #C10V-ABS Price \$62.00 per side  
Also fits 80-82 Corvette

### Additional Information

Inner Seal #9178S  
Inner Bearing #86649  
Inner Race #86610  
Outer Bearing #48548  
Outer Race #48510  
Outer Seal #5113



## 1350 Outer Axles

K.A. Axles offers a forged 1541 axle with a much larger 31 spline shaft versus the standard 17 spline size. Heat-treated to survive a cruel world. These puppies are tough. Incorporates a larger inner bearing with a light press fit for easy maintenance and increases bearing life. Available with standard 7/16" press in studs or beefy 1/2" x 3" press in studs (please specify).

Part #KA 10V-ODAK Price \$900.00 pair



Most Pieces U.S.A. Made



## 1350 Vette Axle Kit

Our 1350 axle kit includes 31 spline outer axles with bearings, drive flanges, bolt on inner and outer flanges, u-joints, bolts, 3 1/2" half-shafts with .134 wall thickness and your choice of 17 or 30 spline inner axles. Also includes standard 7/16" wheel studs or 1/2" x 3" studs. Photo shows one side only, kit naturally includes both sides.

Part #1350-VAK Price \$2000.00 kit

We also offer 1/2 shafts separately

Part #1350-VHS Price \$455.00 pr.



Most Pieces U.S.A. Made



# 1963-1979 CORVETTE

## Inner Axles

G.M. has discontinued the inner axles for 63-79 Vettes. Whats a man supposed to do? Call Tom's of course! We offer good used axles, replaced tip axles that are guaranteed for life against wearing the tip down, K.A. replacement axles with the unique bolt on drive flange so you **can't** over-torque the u-bolts causing premature u-joint failure. K.A.s are available in 17 sp. with standard snap ring axle retention, 17 spline for c-clip axle retention (requires use of 17 sp. c-clip side gears) and also 30 spline inners for abusive applications also retained by a c-clip (requires modifications to posi case and 30 sp. side gears. WOOOH!

MADE IN U.S.A.



Replacement tip axle                      \$126.00 each exch.

### K.A. axles

\$385.00 pair includes drive flanges and bolts

\*Now available HY-TUFF 1350 inners for 30sp. Price \$521.00 Pair

**Note!** For 12 Bolt Center

## 1480 Vette Axle Kit

Our 1480 Axle Kit is the toughest we offer for your Vette. Outer Axles are K.A. 1541,31 spline with your choice of 7/16" or 1/2" x 3" press in wheel studs. Huge 3 1/2" diameter half-shafts with .095 wall thickness. Giant 4 1/2" width with 1 3/8" cup diameter U-joints, and Tom's K.A. 30 spline inner axles. Wow! There's a mouth full. Please specify wheel stud and 10 or 12-bolt center.

Part #1480-VAK                      Price \$2500.00

'63-'67 Battery in front

'68 up Battery box needs to be trimmed for clearance

Most Pieces  
U.S.A. Made

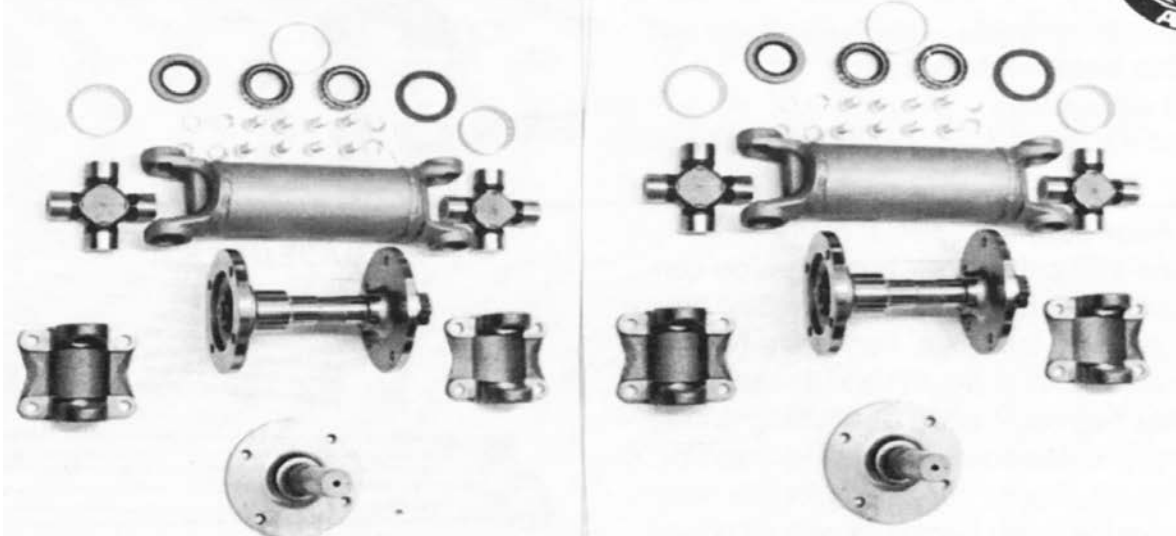

OPTION! Half Shafts now available with .134 wall thickness add \$55.00 to kit price.

\*Now available 4340 inners and outers w/ 200,000 tinsel strength a 25% increase add \$200.00 to kit price & please specify

## 1963-1979 CORVETTE

---

### **Offset Trailing Arm**

This piece of art keeps the wheel in the stock location while allowing a wider tire by following the contour of the frame rail. This beauty accepts the parking brake, is drilled for use with rear sway bar, has a new urethane bushing with sleeve installed and now includes mounting bracket for upper control arms.

**NOTE!** moves the spring in 1-1/4" per side so it does require a shorter main spring and also requires the use of a heavy duty cover.

Part #VOS-TA Price \$537.50 pair

#### **Also available**

New parking brake cable guides \$5.00 ea  
New studs for hub to trailing arm \$2.40 ea

---

**MADE IN U.S.A.**



Allows 68-82 Vettes to use a 5" back spacing on an 8 1/2" to 9" wheel with a 10" or 11" tire.

---

### **Rear Spring**

The stock factory spring doesn't seem to hold up very long, so here's one you can depend on. A High Performance spring with the standard 360 lb rating to be used with the Offset Trailing Arms. We offer the shorter mainspring by itself.

Part #OSTA-MS Price \$97.00

Complete H.P. 7 Leaf with shorter mainspring

Part #OSTA-SK Price \$255.00

**NEW!** We now offer complete H.P. 7 leaf with standard length mainspring.

Part #STA-SK Price \$263.50

---

**Spring is 2-1/4" Wide**

**MADE IN U.S.A.**



### **Locator Kit**

This nifty kit secures the crossmember to the frame, minimizing the up and down flex while eliminating wheel hop and that horrible bang noise that occurs on initial launch and between shifts.

**Amen.**

Also includes front tongue bushing eliminator and new bolts so installations a snap.

Proven so successful

Part #10V-LK Price \$80.00

---

**MADE IN U.S.A.**

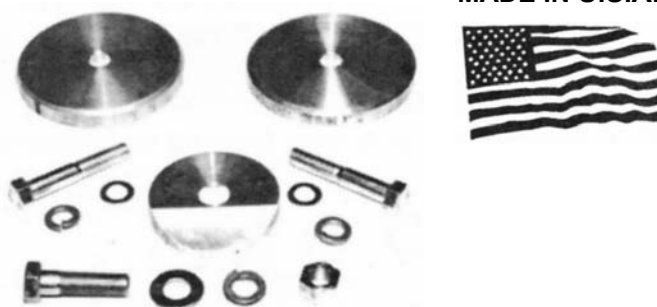

### **Rear Camber Control Rods**

When using slicks the stock bushing type control rods don't hold up very at all. These bad boys don't use crummy bushings, they have huge 5/ 8" helm ends with left and right hand threads making for easy alignment while eliminating annoying binding problems and improving handling. Ahh American ingenuity. Don't settle for less when you can have the best. Complete with all necessary hardware.

Part #V-RCCR Price \$350.00 set

Also fits 80-82 Vette

---

**MADE IN U.S.A.**

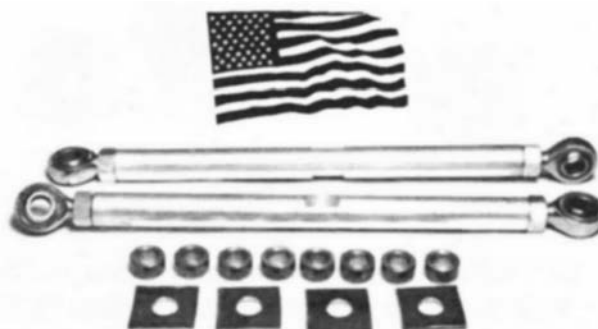

## Frame Reinforcers

The factory frame needs to be reinforced when used for performance applications. Frame cracks, car gets loose, **DO IT NOW!** Don't take a chance, someone could get hurt. Photo shows where they go. 4 piece kit.

Part #V-FR                      Price \$45.00

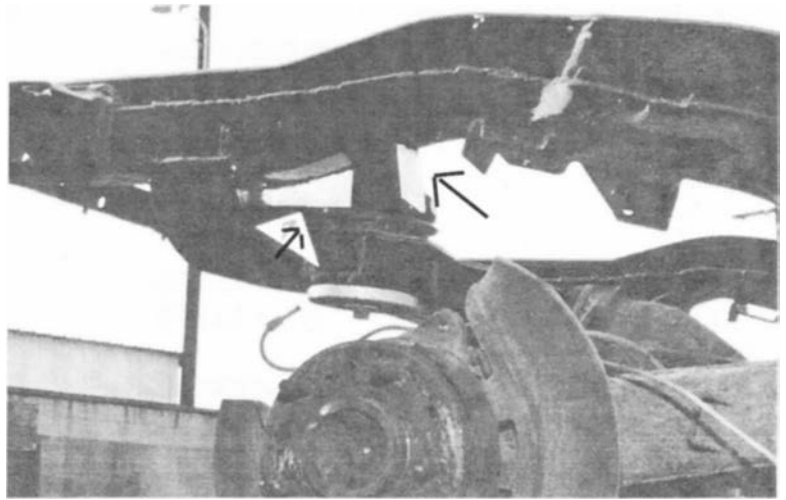

MADE IN U.S.A.



*NOT! for Handling  
Purposes  
Safety Device Only!*

\* **NOTE!** Not Legal for Stock Eliminator

MADE IN U.S.A.



## Upper Control Arms

N.H.R.A. Approved! You go 10.99 & faster, you use these! We've designed our upper control arms to match the half-shaft angle. The upper plate is sandwiched in between the rear cover and cross member. The arm goes over and connects to our trailing arm utilizes 1/2" Heim ends, threaded arms for adjustments. Also includes half-shaft safety loops which can be bolted or welded in place (welded is preferred). They are 2 pieces for easy half-shaft removal.

Part #V-UCR                      Price \$640.00

Half-Shaft Loops Only

Part #10V-HS loops              Price \$67.00 Pr.

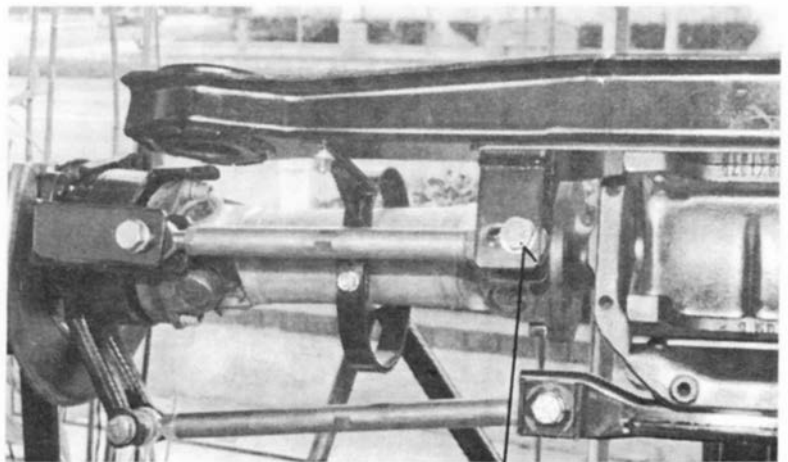

\* **NOTE!** Not Legal for Stock Eliminator  
**NOTE!**

Upper adjuster must not be tight  
it must be able to float back & forth!

## 63-79 CORVETTE MISC"

### **Parking Brakes**

We now offer parking brake shoes and hardware kits.

Parking brake Shoes

Part #V-PB Price \$43.00 Both Sides

Parking brake hardware

Part #V-PBH Price \$43.00 Both Sides



### **Dust Shields**

**NEW!** Now available are new shields that actually fit like their suppose to. Available in gold or silver finish.

#### **Gold**

L.H. Part #GVDS-LH Price \$33.00

R.H. Part #GVDS-RH Price \$33.00

#### **Silver**

L.H. Part #SVDS-LH Price \$33.00

R.H. Part #SVDS-RH Price \$33.00



### **New! Tom's Billet Caliper Brackets**

The Factory brackets are prone to bending so we made them nice and beefy out of Billet Aluminum, in the U.S.A. of Course.

Part #TBDB-CB Price \$300.00 pair

**NOTE!** For disc brake kits see page 132



### **Lower Shock Mounts**

These puppies seem to get beat up quite often so we offer new one's. What can I say? Aftermarket

Right Side

Part #V-RSM Price \$54.00

Left Side

Part #V-LSM Price \$54.00



### **Camber Rod Bracket**

63 thru 68 Vette's use a 1" higher mounting point for your chamber rods. 69 thru 79 uses a lower mounting point to achieve better geometry for the camber rods. This is a aftermarket replacement for 69-79 using G.M. Tooling.

Part #VCRB Price \$152.00

We also offer our modified camber rod bracket for an additional 1" drop for even better geometry when used in drag or road racing helps to keep camber rod at 0°

Part #VCRB-MOD Price \$230.00

**Note!** 63-79 Vette's using our 1480 axle kit must use later bracket.

